

Revision History

| Rev | Description | Date | Approved |
|-----|-----------------------|----------|----------|
| A | New Drawing & OEM No. | 07/04/22 | JB |

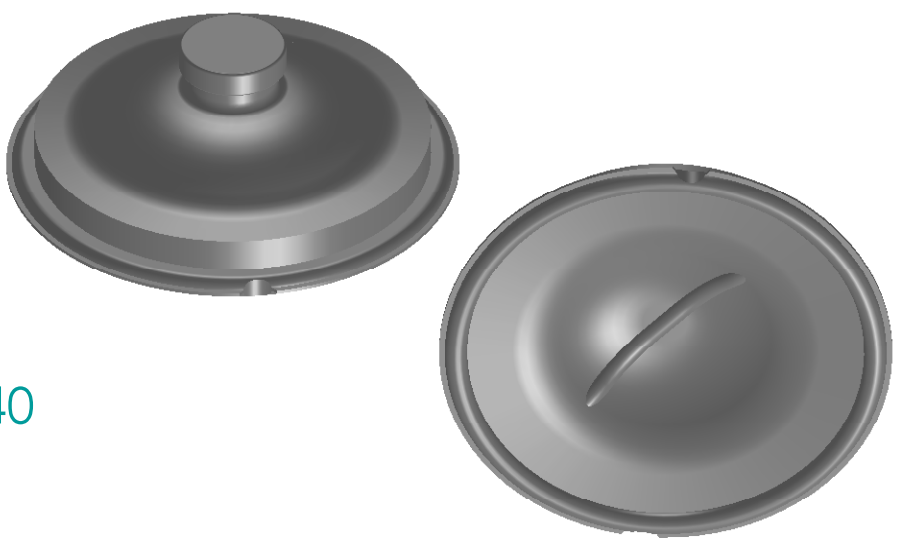
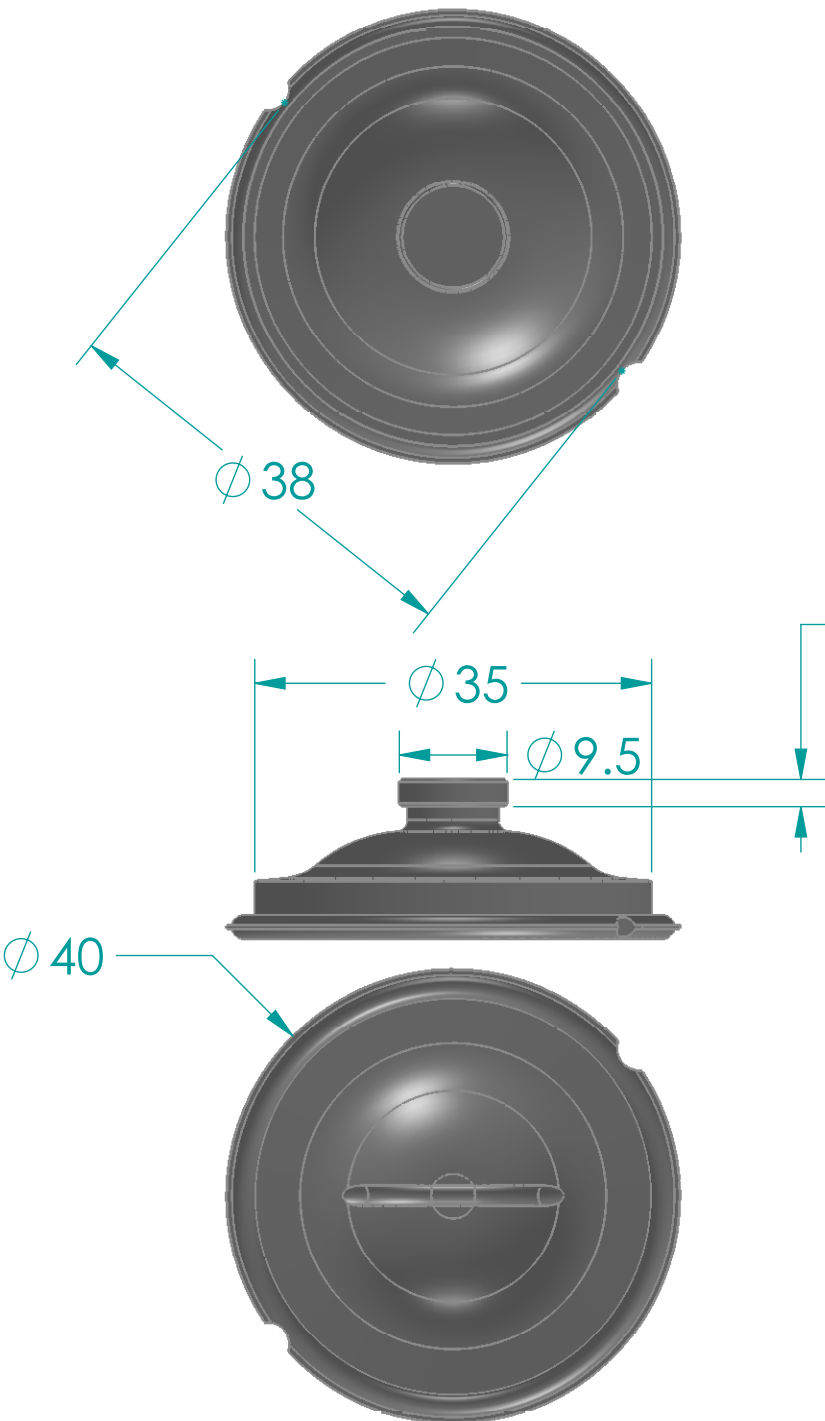

Replacement Diaphragm for:-
 OEM PART NUMBER = DA010B1
 USED ON 3/8" (DN10) Diaphragm Valve

Disclaimer - Diaphragm Direct® does not manufacture, represent, nor sell OEM valves or diaphragms manufactured by any other company. Diaphragm Direct® brand diaphragms are not sponsored by any other manufacturers. Any name, model, part number, brand, image, material or referral is for descriptive purposes only. Diaphragm Direct® brand replacement diaphragms are guaranteed to fit OEM equipment and meet or exceed OEM specifications. Diaphragm Direct® brand replacement diaphragms are covered by the standard Diaphragm Direct® limited product warranty.

| | | | | | |
|--|-----------|----------|---|-----------------------|--|
| | Name | Date | DIAPHRAGM DIRECT | | |
| Drawn | M.Mc Keon | 12/03/22 | | | |
| Checked | | | | | |
| <u>Material - Butyl (IIR)</u> | | | TITLE <b style="color: teal;">DD02-SIIR | | |
| Complies with CFR 177.2600 and Conforms to USP Class VI Biological Reactivity Tests Section #87 and #88 | | | Size A | FOOT PRINT DIMENSIONS | |
| | | | Rev A | Rev A | |
| | | | DD02-SIIR-RevA | | |
| SCALE: 3:2 mm | | Job: 47 | Sheet 1 of 1 | | |